



AISI S200-12



# **AISI STANDARD**

## **North American Standard for Cold-Formed Steel Framing — General Provisions**

2012 Edition

## DISCLAIMER

The material contained herein has been developed by the American Iron and Steel Institute (AISI) Committee on Framing Standards. The Committee has made a diligent effort to present accurate, reliable, and useful information on cold-formed steel framing design and installation. The Committee acknowledges and is grateful for the contributions of the numerous researchers, engineers, and others who have contributed to the body of knowledge on the subject. Specific references are included in the *Commentary*.

With anticipated improvements in understanding of the behavior of cold-formed steel framing and the continuing development of new technology, this material will become dated. It is anticipated that AISI will publish updates of this material as new information becomes available, but this cannot be guaranteed.

The materials set forth herein are for general purposes only. They are not a substitute for competent professional advice. Application of this information to a specific project should be reviewed by a design professional. Indeed, in many jurisdictions, such review is required by law. Anyone making use of the information set forth herein does so at their own risk and assumes any and all liability arising therefrom.

1st Printing – April 2013

Copyright American Iron and Steel Institute 2012

## PREFACE

The American Iron and Steel Institute (AISI) Committee on Framing Standards has developed AISI S200, *North American Standard for Cold-Formed Steel Framing - General Provisions*, to address requirements for construction with cold-formed steel framing that are common to prescriptive and engineered design. This standard is intended for adoption and use in the United States, Canada and Mexico. This edition supersedes the previous edition, designated as AISI S200-2007.

Compared with the 2007 edition of the standard, the following major revisions were made:

- (1) Consolidations and clarifications were made between AISI cold-formed steel framing standards regarding applicable material, material specification, base steel thickness, manufacturing tolerances, and product dimensions. As a result, the following sections were revised: A3, Material; A4, Corrosion Protections; and A5, Products.
- (2) Section C3.4.4, End Bearing, was revised to clarify when the stud end gap needs to be considered and specified.
- (3) Provisions related to *nonstructural members* were moved from this standard to AISI S220. Changes were made in Sections A1, Scope; A3, Material; A4, Corrosion Protection; and Section A5, Products.
- (4) Section A2, Definitions, was revised to include those used in other *cold-formed steel* framing standards.
- (5) Section A6, Referenced Documents, was updated.

While not necessary, use of the more stringent requirements for *structural members* that are in this standard for *nonstructural members* should be permitted, since these should demonstrate equivalent performance for the intended use to those specified in AISI S220.

The Committee acknowledges and is grateful for the contributions of the numerous engineers, researchers, producers and others who have contributed to the body of knowledge on the subjects. The Committee wishes to also express its appreciation for the support of the Canadian Sheet Steel Building Institute.

**This Page is Intentionally Left Blank.**

**AISI COMMITTEE ON FRAMING STANDARDS**

Richard Haws, <i>Chairman</i>	Nucor Corporation
Steve Fox, <i>Vice Chairman</i>	Canadian Sheet Steel Building Institute
Helen Chen, <i>Secretary</i>	American Iron and Steel Institute
Don Allen	DSi-Engineering, LLC
Bill Babich	ITW Building Components Group
Jeff Brink	National Council of Structural Engineers Association
Brad Cameron	Cameron & Associates Engineering
Randy Daudet	Simpson-Strong Tie
Nader Elhajj	FrameCAD Solutions
Pat Ford	Steel Framing Industry Association
Curt Kinney	Super Stud Building Products
Jeff Klaiman	ADTEK Engineers
Roger LaBoube	Wei-Wen Yu Center for Cold-Formed Steel Structures
Rob Madsen	Supreme Steel Framing System Association
John Matsen	Matsen Ford Design Associates
Cris Moen	Virginia Polytechnic Institute and State University
Jim Moses	LiteSteel Technologies America
Kenneth Pagano	Scosta Corporation
Mike Pellock	Aegis Metal Framing
Nabil Rahman	The Steel Network
Greg Ralph	ClarkDietrich Building Systems
Ben Schafer	Johns Hopkins University
Fernando Sesma	California Expanded Metal Products
Sutton Stephens	Pacific Northwest Engineering
Tom Trestain	T.W.J. Trestain Structural Engineering
Steven Walker	Steven H. Walker, P. Eng.
Robert Wessel	Gypsum Association
Lei Xu	University of Waterloo
Cheng Yu	University of North Texas
Rahim Zadeh	Steel Stud Manufacturers Association

**GENERAL PROVISIONS SUBCOMMITTEE**

Don Allen, <i>Chairman</i>	DSi-Engineering, LLC
Helen Chen, <i>Secretary</i>	American Iron and Steel Institute
Bill Babich	ITW Building Components Group
Jeff Brink	National Council of Structural Engineers Association
Randy Daudet	Simpson Strong-Tie
Jim DesLaurier	Marino\WARE
Nader Elhajj	FrameCAD Solutions
Pat Ford	Steel Framing Industry Association
Steve Fox	Canadian Sheet Steel Building Institute
Richard Haws	Nucor Corporation
Curt Kinney	Super Stud Building Products, Inc.
Jeff Klaiman	ADTEK Engineers
Roger LaBoube	Wei-Wen Yu Center for Cold-Formed Steel Structures
Stephen Linch	Telling Industries
John Matsen	Matsen Ford Design Associates
Brian McGloughlin	MBA Building Supplies
Jim Moses	LiteSteel Technologies America, LLC
Kenneth Pagano	Scosta Corporation
Greg Ralph	ClarkDietrich Building Systems
Fernando Sesma	California Expanded Metal Products
Rahim Zadeh	Steel Stud Manufacturers Association

**TABLE OF CONTENTS**  
**NORTH AMERICAN STANDARD FOR COLD-FORMED STEEL FRAMING —**  
**GENERAL PROVISIONS**

<b>DISCLAIMER .....</b>	<b>ii</b>
<b>PREFACE.....</b>	<b>iii</b>
<b>AIISI COMMITTEE ON FRAMING STANDARDS .....</b>	<b>v</b>
<b>GENERAL PROVISIONS SUBCOMMITTEE .....</b>	<b>vi</b>
<b>NORTH AMERICAN STANDARD FOR COLD-FORMED STEEL FRAMING – GENERAL PROVISIONS ....</b>	<b>1</b>
<b>A. GENERAL .....</b>	<b>1</b>
A1 Scope.....	1
A2 Definitions .....	1
A3 Material .....	7
A4 Corrosion Protection .....	7
A5 Products .....	8
A5.1 Base Steel Thickness.....	8
A5.2 Minimum Flange Width.....	8
A5.3 Product Designator .....	8
A5.4 Manufacturing Tolerances .....	8
A5.5 Product Identification.....	10
A6 Referenced Documents .....	10
<b>B. MEMBER DESIGN .....</b>	<b>12</b>
B1 Members .....	12
B2 Member Condition .....	12
B2.1 Web Holes .....	12
B2.2 Cutting, Patching and Splicing.....	12
<b>C. INSTALLATION .....</b>	<b>13</b>
C1 In-Line Framing .....	13
C2 Installation Tolerances .....	13
C2.1 Foundation .....	13
C2.2 Ground Contact .....	13
C2.3 Floors.....	14
C2.4 Walls.....	14
C2.5 Roofs and Ceilings.....	14
<b>D. CONNECTIONS.....</b>	<b>16</b>
D1 Screw Connections .....	16
D1.1 Steel-to-Steel Screws .....	16
D1.2 Sheathing Screws.....	16
D1.3 Installation.....	16
D1.4 Stripped Screws .....	16
D1.5 Spacing and Edge Distance.....	16
D1.6 Gypsum Board.....	16
D2 Welded Connections .....	16
D3 Other Connections.....	17
D3.1 Bolts.....	17
D3.2 Other Connectors .....	17
D3.3 Connection to Other Materials .....	17
<b>E. MISCELLANEOUS.....</b>	<b>18</b>
E1 Utilities .....	18

---

E1.1	Holes .....	18
E1.2	Plumbing .....	18
E1.3	Electrical.....	18
E2	Insulation .....	18
E2.1	Mineral Fiber Insulation.....	18
E2.2	Other Insulation.....	18



## NORTH AMERICAN STANDARD FOR COLD-FORMED STEEL FRAMING – GENERAL PROVISIONS

### A. GENERAL

#### A1 Scope

This standard shall apply to the design and installation of *structural members* utilized in *cold-formed steel* framing applications where the specified minimum *base steel thickness* is not greater than 118 *mils* (0.1180 inches) (2.997 mm). Elements not specifically addressed by this standard shall be constructed in accordance with *applicable building code* requirements or an *approved* design.

This standard shall not preclude the use of other materials, assemblies, structures or designs not meeting the criteria herein, when the other materials, assemblies, structures or designs demonstrate equivalent performance for the intended use to those specified in this standard. Where there is a conflict between this standard and other reference documents, the requirements contained within this standard shall govern.

This standard includes Sections A through E in their entirety.

#### A2 Definitions

In this standard, “shall” is used to express a mandatory requirement, i.e., a provision that the user is obliged to satisfy in order to comply with the standard. Provisions described as “permitted” are optional, and the election to use such provisions is at the discretion of the user.

Where the following terms appear in this standard in italics, they shall have the meaning herein indicated. Terms included in square brackets shall be specific to *Limit States Design (LSD)* terminology. Where a country is indicated in square brackets following the definition, the definition shall apply only in the country indicated. Terms not defined in Section A2 shall have the ordinary accepted meaning for the context for which they are intended.

*Adjusted Shear Resistance*. In *Type II shear walls*, the unadjusted shear resistance multiplied by the shear resistance adjustment factor.

*Amplified Seismic Load*. Load determined in accordance with the *applicable building code* seismic load combinations that includes the system overstrength factor,  $\Omega_o$ , for *strength design (LRFD)* or for *allowable strength design (ASD)*. [USA and Mexico]

*ASD (Allowable Strength Design)*. Method of proportioning structural components such that the *allowable strength* equals or exceeds the *required strength* of the component under the action of the *ASD load combinations*. [USA and Mexico]

*ASD Load Combination*. Load combination in the *applicable building code* intended for *allowable stress design (allowable strength design)*. [USA and Mexico]

*Allowable Strength*. Nominal strength divided by the safety factor  $R_n/\Omega$ . [USA and Mexico]

*Allowable Stress Design*. Also known as *allowable strength design*, an outdated term used in some reference documents. [USA and Mexico]

*Applicable Building Code*. The building code under which the building is designed.

*Approved*. Approved by the authority having jurisdiction or *design professional*.

*Available Strength*. Design strength or *allowable strength*, as appropriate. [USA and Mexico]

*Average Grade*. The average elevation of the finished ground level adjoining the building at

all exterior walls.

*Base Steel Thickness.* The thickness of bare steel exclusive of all coatings.

*Bearing Stiffener.* Additional material that is attached to the *web* to strengthen the member against web crippling. Also called a *web stiffener*.

*Blocking.* *C-shaped* member, break shape, flat *strap* material, or component assemblies attached to *structural members*, flat *strap* or sheathing panels to transfer shear forces or stabilize members.

*Boundary Member.* *Diaphragm* and *shear wall boundary member* to which the *diaphragm* transfers forces. *Boundary members* include chords and drag struts at *diaphragm* and *shear wall* perimeters, interior openings, discontinuities and re-entrant corners.

*Braced Wall Line.* A wall that is constructed to resist racking from seismic or wind forces and that contains a series of *Type I braced wall panels* or *Type II braced walls*.

*Bracing.* Structural elements that are installed to provide restraint or support (or both) to other framing members so that the complete assembly forms a stable structure.

*Capacity Based Design.* Method for designing a *seismic force resisting system* in which a) specific elements or mechanisms are designed to dissipate energy; b) all other elements are sufficiently strong for this energy dissipation to be achieved; c) structural integrity is maintained; d) elements and connections in the horizontal and vertical *load* paths are designed to resist these seismic *loads* and corresponding principal and companion *loads* as defined by the NBCC; e) *diaphragms* and *collector* elements are capable of transmitting the *loads* developed at each level to the vertical *seismic force resisting system*; and f) these *loads* are transmitted to the foundation. [Canada]

*Ceiling Joist.* A horizontal *structural member* that supports ceiling components and which may be subject to attic *loads*.

*Chord.* Member of a *shear wall* or *diaphragm* that forms the perimeter, interior opening, discontinuity or re-entrant corner.

*Chord Member.* A *structural member* that forms the top or bottom component of a *truss*.

*Chord Splice.* The connection region between two *truss chord members* where there is no change in slope.

*Chord Stud.* Axial load-bearing studs located at the ends of *Type I braced wall panels* or *Type II braced walls*.

*Clip Angle.* An L-shaped short piece of steel (normally with a 90-degree bend) typically used for *connections*.

*Cold-Formed Sheet Steel.* Sheet steel or strip steel that is manufactured by (1) press braking blanks sheared from sheets or cut length of coils or plates, or by (2) continuous roll forming of cold- or hot-rolled coils of sheet steel; both forming operations are performed at ambient room temperature, that is, without any addition of heat such as would be required for hot forming.

*Cold-Formed Steel.* See *Cold-Formed Sheet Steel*.

*Collector.* Also known as a drag strut, a member that serves to transfer forces between *diaphragms* and members of the lateral force resisting system.

*Component.* See *structural component*.

*Connection.* Combination of structural elements and joints used to transmit forces between two or more members.

*Cripple Stud.* A *stud* that is placed between a *header* and a window or door head *track*, a

*header* and wall top *track*, or a window sill and a bottom *track* to provide a backing to attach finishing and sheathing material.

*C-Shape*. A cold-formed steel shape used for structural and nonstructural members consisting of a web, two (2) flanges and two (2) lips (edge stiffeners).

*Curtain Wall*. A wall that transfers transverse (out of plane) *loads* and is limited to a superimposed vertical *load*, exclusive of sheathing materials, of not more than 100 lb/ft (1.46 kN/m), or a superimposed vertical *load* of not more than 200 lbs (0.890 kN).

*Deflection Track*. A *track* manufactured with extended *flanges* and used at the top of a wall to provide for vertical movement of the structure, independent of the wall *stud*.

*Design Load*. Applied *load* determined in accordance with either *LRFD load combinations* or *ASD load combinations*, whichever is applicable. [USA and Mexico]

*Design Professional*. An individual who is registered or licensed to practice their respective design profession as defined by the statutory requirements of the state, province or territory in which the project is to be constructed.

*Design Strength*. *Resistance Factor* multiplied by the *nominal strength*,  $\phi R_n$ . [USA and Mexico]

*Design Thickness*. The steel thickness used in design.

*Designation Thickness*. The minimum *base steel thickness* expressed in *mils* and rounded to a whole number.

*Diaphragm*. Roof, floor or other membrane or bracing system that transfers in-plane forces to the lateral force resisting system.

*Eave Overhang*. The horizontal projection of the roof measured from the outside face of exterior wall framing to the outside edge of the roof.

*Edge Stiffener*. See *Lip*.

*Factored Load*. Product of a *specified load* and appropriate *load factor*. [Canada]

*Factored Resistance*. Product of *nominal resistance* and appropriate *resistance factor*. [Canada]

*Fiberboard*. A fibrous, homogeneous panel made from lignocellulosic fibers (usually wood or cane) and having a density of less than 31 pounds per cubic foot (pcf) (497 kg/m<sup>3</sup>) but more than 10 pcf (160 kg/m<sup>3</sup>).

*Flange*. For a *C-shape*, *U-shape* or *track*, that portion of the framing member that is perpendicular to the *web*. For a furring channel, that portion of the framing member that connects the *webs*.

*Floor Joist*. A horizontal *structural member* that supports floor *loads* and superimposed vertical *loads*.

*Girt*. Horizontal *structural member* that supports wall panels and is primarily subjected to bending under horizontal *loads*, such as wind *load*.

*Grade*. The designation of the minimum *yield strength*.

*Gusset Plate*. A *structural member* used to facilitate the *connection* of *truss chord* or *web members* at a *heel*, *ridge*, other pitch break, or *panel point*.

*Hat-Shape*. A singly-symmetric shape consisting of at least two vertical *webs* and a horizontal stiffened *flange* which is used as a *chord member* in a *truss*.

*Heel*. The *connection* region between the top and bottom *truss chords* of a non-parallel *chord truss*.

*Header*. A horizontal structural framing member used over floor, roof or wall openings to transfer *loads* around the opening to supporting structural framing members.

*Hold-Down (tie-down)*. A device used to resist overturning forces in a shear wall, or uplift forces in a *cold-formed steel* framing member.

*Jack Stud*. A *stud* that does not span the full height of the wall and provides bearing for *headers*.

*Joist*. A *structural member* primarily used in floor and ceiling framing.

*King Stud*. A *stud*, adjacent to a *jack stud*, that spans the full height of the wall and supports vertical and lateral loads.

*Light-Frame Construction*. Construction where the vertical and horizontal structural elements are primarily formed by a system of repetitive *cold-formed steel* or wood framing members.

*Limit States*. Those conditions in which a structural member ceases to fulfill the function for which it was designed. Those states concerning safety are called the ultimate limit states. The ultimate limit state for strength is the maximum *load-carrying capacity*. *Limit states* that restrict the intended use of a member for reasons other than safety, such as deflection and vibration, are called *serviceability limit states*. [Canada]

*LSD (Limit States Design)*. Method of proportioning *structural components* (members, connectors, connecting elements and assemblages) such that no applicable *limit state* is exceeded when the structure is subjected to all appropriate *load combinations*. [Canada]

*Lip*. That part of a framing member that extends from the *flange* as a stiffening element.

*Load*. Force or other action that results from the weight of building materials, occupants and their possessions, environmental effects, differential movement, or restrained dimensional changes.

*Load Effect*. Forces, stresses, and deformations produced in a *structural component* by the applied loads.

*Load Factor*. Factor that accounts for deviations of the actual *load* from the *nominal load*, for uncertainties in the analysis that transforms the *load* into a *load effect*, and for the probability that more than one extreme *load* will occur simultaneously. [USA and Mexico]

*LRFD (Load and Resistance Factor Design)*. Method of proportioning *structural components* such that the *design strength* equals or exceeds the *required strength* of the *component* under the action of the *LRFD load combinations*. [USA and Mexico]

*LRFD Load Combination*. *Load combination* in the *applicable building code* intended for *Strength Design (Load and Resistance Factor Design)*. [USA and Mexico]

*Mean Roof Height*. The average of the roof eave height and the height to the highest point on the roof surface, except that eave height shall be used for roof angles less than or equal to 10 degrees (0.18 rad).

*Mil*. A unit of measurement equal to 1/1000 inch.

*Multiple Span*. The *span* made by a continuous member having intermediate supports.

*Nominal Load*. Magnitude of the *load* specified by the *applicable building code*. [USA and Mexico]

*Nominal Resistance*. Capacity of a structure or *component* to resist the effects of *loads*, determined in accordance with this standard using specified material strengths and dimensions. [Canada]

*Nominal Strength*. Strength of a structure or *component* (without the *resistance factor* or *safety factor*) to resist the *load effects*, as determined in accordance with this standard. [USA and Mexico]

*Nonstructural Member.* A member in a steel-framed system that is not a part of the gravity load resisting system, lateral force resisting system or building envelope.

*Panel Point.* The connection region between a *web* and *chord member*.

*Pitch Break.* The connection region between two *truss chord members* where there is a change in slope, excluding the *heel*.

*Plan Aspect Ratio.* The ratio of the length (longer dimension) to the width (shorter dimension) of the building.

*Punchout.* A hole made during the manufacturing process in the *web* of a steel framing member.

*Purlin.* Horizontal structural member that supports roof deck and is primarily subjected to bending under vertical *loads* such as snow, wind, or dead *loads*.

*Rake Overhang.* The horizontal projection of the roof measured from the outside face of a gable endwall to the outside edge of the roof.

*Repetitive Framing.* A framing system where the wall, floor and roof *structural members* are spaced no greater than 24 inches (610 mm) on center. Larger spaces are permitted at openings where the structural *loads* are transferred to headers or lintels and supporting *studs, joists* or *rafters*.

*Required Strength.* Forces, stresses, and deformations produced in a structural component, determined by either structural analysis, for the *LRFD* or *ASD load combinations*, as appropriate, or as specified by this standard. [USA and Mexico]

*Resistance Factor* ( $\phi$ ). Factor that accounts for unavoidable deviations of the actual strength from the *nominal strength* [nominal value] and for the manner and consequences of failure.

*Ridge.* The horizontal line formed by the joining of the top edges of two upward sloping roof surfaces.

*Rim Track.* A horizontal *structural member* that is connected to the end of a *floor joist*.

*Roof Rafter.* A horizontal or sloped, *structural member* that supports roof *loads*.

*Safety Factor* ( $\Omega$ ). Factor that accounts for the desired level of safety, including deviations of the actual *load* from the *nominal load* and uncertainties in the analysis that transforms the *load* into a *load effect*, in determining the *nominal strength* and for the manner and consequences of failure. [USA and Mexico]

*Seismic Design Category (SDC).* Classification assigned to a building based upon its importance and the severity of the design earthquake ground motion at the building site as given in the *applicable building code*.

*Seismic Force Resisting System.* That part of the structural system that has been considered in the design to provide the required resistance to the earthquake forces and effects. [Canada]

*Shear Wall.* Wall that provides resistance to lateral *loads* in the plane of the wall and provides stability for the structural system.

*Single Span.* The *span* made by one continuous structural member without any intermediate supports.

*Span.* The clear horizontal distance between bearing supports.

*Specified Load.* Magnitude of the *load* specified by the *applicable building code*, not including *load factors*. [Canada]

*Static Load.* A *load* or series of *loads* that are supported by or are applied to a structure so gradually that forces caused by change in momentum of the *load* and structural elements

can be neglected and all parts of the system at any instant are essentially in equilibrium.

*Steel Sheet.* A thin steel panel used in lieu of structural sheathing for wall bracing applications.

*Strap.* Flat or coiled sheet steel material typically used for *bracing* and *blocking*, which transfers *loads*, by tension and/or shear.

*Strap Bracing.* Steel straps, applied diagonally to form a vertical truss as part of the lateral force resisting system.

*Strength Design.* Also known as *load and resistance factor design*, an outdated term used in some reference documents. [USA and Mexico]

*Structural Component.* Member, connector, connecting element or assemblage.

*Structural Member.* A member that resists *design loads* [*factored loads*] as required by the *applicable building code*, except when defined as a *nonstructural member*.

*Structural Sheathing.* The covering used directly over *structural members* that is capable of distributing *loads*, bracing members, and generally strengthening the assembly.

*Stud.* A vertical framing member in a wall system or assembly.

*Track.* A framing member consisting of only a *web* and two (2) *flanges*. *Track web* depth measurements are taken to the inside of the *flanges*.

*Truss.* A coplanar system of *structural members* joined together at their ends, usually to construct a series of triangles that form a stable beam-like framework.

*Truss Design Engineer.* Person who is licensed to practice engineering as defined by the legal requirements of the jurisdiction in which the building is to be constructed and who supervises the preparation of the *truss design drawings*.

*Truss Designer.* Person responsible for the preparation of the *truss design drawings*.

*Truss Design Drawing.* Written, graphic and pictorial depiction of an individual *truss*.

*Truss Manufacturer.* An individual or organization engaged in the manufacturing of site-built or in-plant *trusses*.

*Truss Member.* A *chord member* or *web member* of a *truss*.

*Type I Braced Wall Panel.* *Type I braced wall panels* are sheathed for the full height of the wall with wood *structural sheathing* panels or *steel sheet* on one side, have no openings, and have continuous sheathing between *hold-down* anchors.

*Type I Shear Wall.* Wall designed to resist in-plane lateral forces that is fully sheathed and that is provided with *hold-down* anchors at each end of the wall segment. *Type I shear walls* are only permitted to have openings where detailing for force transfer around the openings is provided.

*Type II Braced Wall.* *Type II braced walls* are fully sheathed for the full height of the wall with wood *structural sheathing* panels or *steel sheet* on one side, and are permitted to have openings between *hold-down* anchors.

*Type II Shear Wall.* Wall designed to resist in-plane lateral forces that is sheathed with wood structural panels or sheet steel that contains openings, but which has not been specifically designed and detailed for force transfer around wall openings. *Hold-down* anchors for *Type II shear walls* are only required at the ends of the wall.

*Type II Shear Wall Segment.* Section of *shear wall* (within a *Type II shear wall*) with full-height sheathing (i.e., with no openings) and which meets specific aspect ratio limits.

*Web.* That portion of a framing member that connects the *flanges*.

*Web Member.* A structural member in a *truss* that is connected to the top and bottom *chords*, but is not a *chord member*.

*Wind Exposure.* Wind exposure in accordance with the *applicable building code*.

*Yield Strength.* Stress at which a material exhibits a specified limiting deviation from the proportionality of stress to strain as defined by ASTM.

*Z-Shape.* A point-symmetric or non-symmetric section that is used as a *chord member* in a *truss*.

### A3 Material

*Structural members* utilized in *cold-formed steel* framed construction shall be cold-formed to shape from sheet steel complying with the requirements of ASTM A1003/A1003M, subject to the following limitations:

- (a) Type H (high ductility): No limitations.
- (b) Type L (low ductility): Limited to *purlins*, *girts* and *curtain wall studs*. Additional country-specific limitations for *curtain wall studs* are provided in Section A2.3.5 of AISI S100 [CSA S136] Appendix A or B, as applicable.

**For Canada:** Alternatively, *structural members* are permitted to be cold-formed to shape from sheet steel complying with the requirements of ASTM A653/A653M Type SS or ASTM A792/A792M Type SS.

### A4 Corrosion Protection

**A4.1** *Structural members* utilized in *cold-formed steel* framed construction shall have a protective coating as specified in Table A4-1.

**Table A4-1**  
**Coating Designations**

Coating Classification	Coating Designator	Minimum Coating Requirements			
		Zinc Coated <sup>A</sup> oz/ft <sup>2</sup> (g/m <sup>2</sup> )	Zinc Iron <sup>B</sup> oz/ft <sup>2</sup> (g/m <sup>2</sup> )	55% Al-Zinc <sup>C</sup> oz/ft <sup>2</sup> (g/m <sup>2</sup> )	Zinc-5% <sup>D</sup> oz/ft <sup>2</sup> (g/m <sup>2</sup> )
Metallic Coated	CP 60	G60 [Z180]	A60 [ZF180]	AZ50 [AZM150]	CF30 [ZGF90]
	CP 90	G90 [Z275]	Not Applicable	AZ50 [AZM150]	CF45 [ZGF135]
Painted Metallic	PM	The metallic coated substrate shall meet the requirements of metallic coated. In addition, the paint film shall have a minimum thickness of 0.5 mil per side (primer plus topcoat) with a minimum primer thickness of 0.1 mil per side. <sup>E</sup>			

<sup>A</sup> Zinc-coated steel sheet as described in ASTM A653/A653M.

<sup>B</sup> Zinc-iron alloy-coated steel sheet as described in ASTM A653/A653M.

<sup>C</sup> 55% aluminum-zinc alloy-coated steel sheet as described in ASTM A792/A792M.

<sup>D</sup> Zinc-5% aluminum alloy-coated steel sheet as described in ASTM A875/A875M.

<sup>E</sup> In accordance with the requirements of ASTM A1003/A1003M.

**For Canada:** *Structural members* utilized in *cold-formed steel* framed construction shall have a metallic coating of G60 [Z180] complying with the requirements of ASTM A653/A653M or AZ50 [AZM150] complying with the requirements of ASTM A792/A792M.

**A4.2** Additional corrosion protection shall not be required on edges of metallic-coated steel framing members, shop or field cut, punched or drilled.

**A4.3** Unless additional corrosion protection is provided, framing members shall be located within the building envelope and shielded from direct contact with moisture from the ground or the outdoor climate.

**A4.4** Dissimilar metals shall not be used in direct contact with *cold-formed steel* framing members unless *approved* for that application.

**A4.5** *Cold-formed steel* framing members shall not be embedded in concrete unless *approved* for that application.

**A4.6** Fasteners shall have a corrosion resistant treatment, or be manufactured from material not susceptible to corrosion.

## **A5 Products**

### **A5.1 Base Steel Thickness**

The material thickness of framing members, in their end-use, shall meet or exceed the minimum *base steel thickness* values given in an *approved* design or *approved* product standard, such as AISI S201. In no case shall the minimum *base steel thickness* be less than 95% of the *design thickness*.

### **A5.2 Minimum Flange Width**

For *C-shape* members intended to receive sheathing, the minimum *flange* width shall be 1-1/4 inch (31.8 mm). For *track*, the minimum *flange* width shall be 3/4 inch (19.1 mm).

### **A5.3 Product Designator**

References to *structural members* shall use a four-part product designator that identifies the size (both *web* depth and *flange* width), style, and thickness. The standard designator as described (i.e. based on U.S. Customary units) shall be used for either U.S. Customary or SI Metric units. The product designator shall consist of the following sequential codes:

A three or four-digit numeral indicating member *web* depth in 1/100 inch. A letter indicating:

S = *Stud* or *joist* framing member which has *lips*

T = *Track* section

U = Channel or *stud* framing section which does not have *lips*

F = Furring channels

L = Angle or *L-header*

A three-digit numeral indicating *flange* width in 1/100 inch, followed by a dash. A two- or three-digit numeral indicating *designation thickness*.

When specifying material for use in structural applications, the material *grade* used in design shall be identified on the contract documents and when ordering the material.

### **A5.4 Manufacturing Tolerances**

*Structural members* utilized in *cold-formed steel* framed construction shall comply with the manufacturing tolerances listed in Table A5-1.



**Table A5-1  
Manufacturing Tolerances for Structural Members**

Dimension <sup>1</sup>	Item Checked	Studs, in. (mm)	Tracks, in. (mm)
A	Length	+3/32 (2.38)	+ 1/2 (12.7)
		-3/32 (2.38)	-1/4 (6.35)
B <sup>2</sup>	Web Depth	+1/32 (0.79)	+1/32 (0.79)
		-1/32 (0.79)	+1/8 (3.18)
C	Flare	+1/16 (1.59)	+0 (0)
	Overbend	-1/16 (1.59)	-3/32 (2.38)
D	Hole Center Width	+1/16 (1.59)	NA
		-1/16 (1.59)	NA
E	Hole Center Length	+1/4 (6.35)	NA
		-1/4 (6.35)	NA
F	Crown	+1/16 (1.59)	+1/16 (1.59)
		-1/16 (1.59)	-1/16 (1.59)
G <sup>3</sup>	Camber	1/8 per 10 ft (3.13 per 3 m)	1/32 per ft (2.60 per m) 1/2 max (12.7)
H <sup>3</sup>	Bow	1/8 per 10 ft (3.13 per 3 m)	1/32 per ft (2.60 per m)
			1/2 max (12.7)
I	Twist	1/32 per ft (2.60 per m)	1/32 per ft (2.60 per m)
		1/2 max (12.7)	1/2 max (12.7)

<sup>1</sup> All measurements shall be taken not less than 1 ft (305 mm) from the end.

<sup>2</sup> Outside dimension for *stud*; inside for *track*.

<sup>3</sup> 1/8 inch per 10 feet represents L/960 maximum for overall camber and bow. Thus, a 20-foot long member would have 1/4-inch permissible maximum; a 5-foot long member would have 1/16-inch permissible maximum.

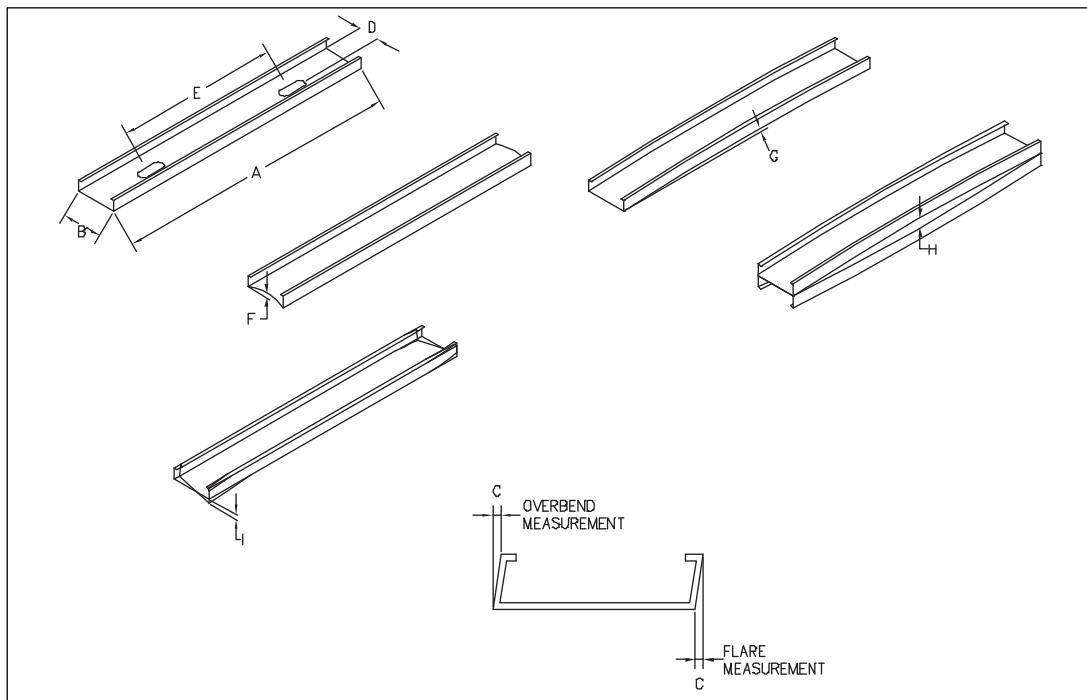

**Figure A5-1 Manufacturing Tolerances for Structural Members**

## A5.5 Product Identification

Framing members used in *cold-formed steel* framed construction shall be identified in accordance with the requirements of this section.

### A5.5.1 Identification of Groups of Like Members

Groups of like members shall be marked with a label, or a tag attached thereto. Marking shall include the roll-former's identification (name, logo, or initials), length, quantity, and roll-former's member designator including member depth, flange size, and minimum steel thickness in mils or inches exclusive of protective coating.

### A5.5.2 Identification of Individual Framing Members

In addition to the marking referenced in A5.5.1, individual framing members shall have a legible label, stencil, or embossment, at a maximum distance of 96 in. (2440 mm) on center, on the member, with the following minimum information:

- (1) The roll-former's identification (that is, name, logo, or initials).
- (2) The minimum steel thickness, in mils or inches, exclusive of protective coatings.
- (3) The minimum *yield strength* in kip per square inch (megapascals).
- (4) The appropriate protective coating designator in accordance with Section A4.

**For Canada:** In addition to the marking referenced in A5.5.1, individual framing members shall have a legible label, stencil, or embossment, at a maximum distance of 96 in. (2440 mm) on centre, on the member, with the following minimum information:

- (1) The manufacturer's identification (name, logo, or initials); and
- (2) The minimum steel thickness (in mils, inches or millimeters) exclusive of protective coatings.

## A6 Referenced Documents

The following documents or portions thereof are referenced within this standard and shall be considered as part of the requirements of this document.

1. American Iron and Steel Institute (AISI), 25 Massachusetts Avenue, NW, Suite 800, Washington, DC 20001:
  - AISI S100-12, *North American Specification for the Design of Cold-Formed Steel Structural Members*
  - AISI S201-12, *North American Standard for Cold-Formed Steel Framing – Product Data*
2. ASTM International, 100 Barr Harbor Drive, West Conshohocken, PA 19428-2959:
  - ASTM A653/A653M-11, *Specification for Steel Sheet, Zinc-Coated (Galvanized) or Zinc-Iron Alloy-Coated (Galvannealed) by the Hot-Dip Process*
  - ASTM A792/A792M-10, *Specification for Steel Sheet, 55% Aluminum-Zinc Alloy-Coated by the Hot-Dip Process*
  - ASTM A875/A875M-10, *Specification for Steel Sheet, Zinc-5% Aluminum Alloy-Coated by the Hot-Dip Process*
  - ASTM A1003/A1003M-11, *Standard Specification for Sheet Steel, Carbon, Metallic and Non-Metallic Coated for Cold-Formed Framing Members*
  - ASTM C954-10, *Standard Specification for Steel Drill Screws for the Application of Gypsum Panel Products or Metal Plaster Bases to Steel Studs From 0.033 in. (0.84 mm) to 0.112 in. (2.84 mm) in Thickness*

*ASTM C1002-07, Steel Self-Piercing Tapping Screws for the Application of Gypsum Panel Products or Metal Plaster Bases to Wood Studs or Steel Studs*

*ASTM, C1513-10, Standard Specification for Steel Tapping Screws for Cold-Formed Steel Framing Connections*

3. American Welding Society, 8669 Doral Boulevard, Suite 130, Doral, FL 33166:

*AWS D1.3, Structural Welding Code-Sheet Steel, 1998 Edition*

4. Canadian Standards Association, 5060 Spectrum Way, Mississauga, Ontario, Canada L4W 5N6:

*CAN/CSA-S136-12, North American Specification for the Design of Cold-Formed Steel Structural Members*

## **B. MEMBER DESIGN**

### **B1 Members**

Framing members shall be designed in accordance with AISI S100 [CSA S136].

### **B2 Member Condition**

Framing members shall be as specified by an *approved* design or *approved* design standard. The members shall be in good condition. Damaged members shall be replaced or repaired in accordance with the *approved* design or *approved* design standard.

#### **B2.1 Web Holes**

Holes in *webs* of framing members shall be in conformance with an *approved* design, AISI S100 [CSA S136], or an *approved* design standard. *Webs* with holes not conforming to the above shall be reinforced or patched in accordance with an *approved* design or *approved* design standard.

#### **B2.2 Cutting, Patching and Splicing**

##### **B2.2.1 Cutting and Patching**

All cutting of framing members shall be done by sawing, abrasive cutting, shearing, plasma cutting or other *approved* methods. Cutting or notching of *structural members*, including *flanges* and *lips* of *joists*, *studs*, *headers*, *rafters*, and *ceiling joists*, or the patching of those cuts shall not be permitted without an *approved* design or in accordance with an *approved* design standard.

##### **B2.2.2 Splicing**

Splicing of *joists*, *studs* and other *structural members* shall not be performed without an *approved* splice design or in accordance with an *approved* design standard.

## C. INSTALLATION

### C1 In-Line Framing

Each *joist, rafter, truss*, and structural wall *stud* (above or beneath) shall be aligned vertically according to the limits depicted in Figure C1-1. The alignment tolerance is not required when a structural *load* distribution member is specified in accordance with an *approved* design or *approved* design standard.

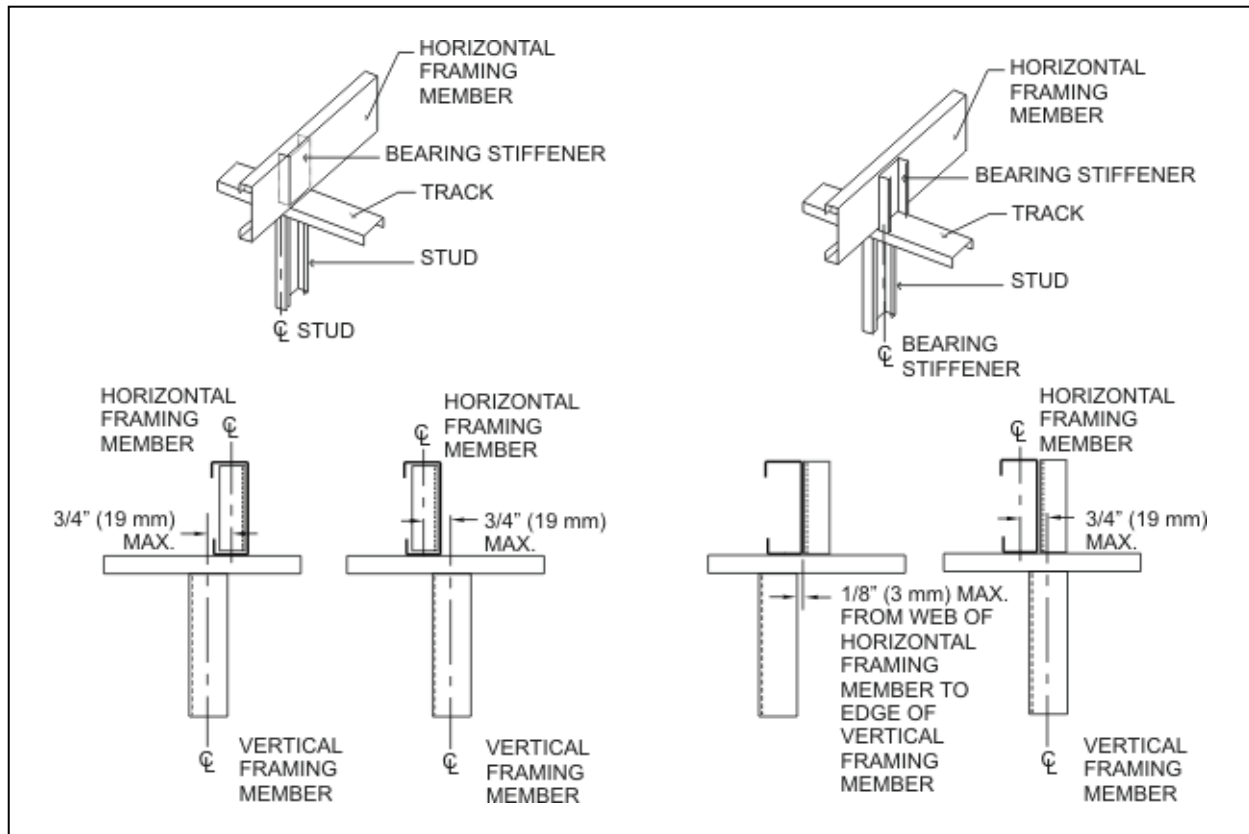

Figure C1-1 In-Line Framing

### C2 Installation Tolerances

#### C2.1 Foundation

The foundation shall be level and free from defects beneath *load* bearing walls. If the foundation is not level, provisions shall be made to provide a uniform bearing surface with a maximum 1/4-inch (6.4 mm) gap between the bottom *track* or *rim track* and the foundation. This shall be accomplished through the use of *load* bearing shims or grout provided between the underside of the wall bottom *track* or *rim track* and the top of the foundation wall or slab at *stud* or *joist* locations.

#### C2.2 Ground Contact

Framing shall not be in direct contact with the ground unless specified by an *approved* design. Framing not in direct contact with the ground shall be installed at a height above the ground in accordance with the *applicable building code*.

## **C2.3 Floors**

### **C2.3.1 Plumbness and Levelness**

*Floor joists* and *floor trusses* shall be installed plumb and level, except where designed as sloping members.

### **C2.3.2 Floor Span Capacity**

*Floor joist* and *floor truss* spacing shall not exceed the span capacity of the floor sheathing material.

### **C2.3.3 Alignment**

*Floor joists* and *floor trusses* shall comply with the alignment requirements of Section C1.

### **C2.3.4 Bearing Width**

*Floor joists* and *floor trusses* shall be installed with full bearing over the width of the bearing wall beneath, a minimum 1-1/2 inch (38.1 mm) bearing end, or in accordance with an *approved* design or *approved* design standard.

### **C2.3.5 Web Separation**

*Floor joist webs* shall not be in direct contact with *rim track webs*.

## **C2.4 Walls**

### **C2.4.1 Straightness, Plumbness and Levelness**

Wall *studs* shall be installed plumb, except where designed as sloping members. Wall *track* members shall be installed level except where designed as sloping members.

### **C2.4.2 Sheathing Span Capacity**

Wall *stud* spacing shall not exceed the span capacity of the sheathing material.

### **C2.4.3 Alignment**

Structural wall *studs* shall comply with the alignment requirements of Section C1 for in-line framing.

### **C2.4.4 End Bearing**

Ends of axial *load* bearing wall *studs* shall have square end cuts and shall be seated tight against the *tracks* with a maximum gap tolerance of 1/8 inch (3.18 mm) between the end of wall framing member and the *web* of the *track*. For thicknesses of the *stud* or *track* greater than 54 mil (0.054 inches (1.37 mm)), special consideration shall be given to the end gap and the maximum end gap shall be specified by the *Building Designer*.

## **C2.5 Roofs and Ceilings**

### **C2.5.1 Plumbness and Levelness**

Roof and ceiling framing members shall be installed plumb and level, except where designed as sloping members.

**C2.5.2 Sheathing Span Capacity**

The spacing of roof and ceiling framing members shall not exceed the span capacity of the ceiling or roof sheathing material.

**C2.5.3 Alignment**

Roof and ceiling framing members shall comply with the alignment requirements of Section C1 for in-line framing.

**C2.5.4 Bearing**

*Ceiling joists* and roof *trusses* shall be installed with full bearing over the width of the bearing wall beneath, or a minimum 1-1/2 inch (38.1 mm) bearing end condition, or in accordance with an *approved* design or *approved* design standard.

## D. CONNECTIONS

### D1 Screw Connections

#### D1.1 Steel-to-Steel Screws

Screw fasteners for steel-to-steel *connections* shall be in compliance with ASTM C1513 or an *approved* design or *approved* design standard. Use of a larger-than-specified screw size is permitted, providing that the design and installation are in accordance with the minimum spacing and edge distance requirements.

#### D1.2 Sheathing Screws

Screw fasteners for structural sheathing to steel *connections* shall be in compliance with ASTM C1513 or an *approved* design or *approved* design standard.

#### D1.3 Installation

Screw fasteners shall extend through the steel *connection* a minimum of three (3) exposed threads. Screw fasteners shall penetrate individual components of connections without causing permanent separation between components.

#### D1.4 Stripped Screws

Stripped screw fasteners in direct tension shall be considered ineffective. Stripped screw fasteners in shear shall only be considered effective when the number of stripped screw fasteners considered effective does not exceed twenty-five percent (25%) of the total number of screw fasteners considered effective in the *connection*.

#### D1.5 Spacing and Edge Distance

For screw fasteners in steel-to-steel *connections* to be considered fully effective, the minimum center-to-center spacing and edge distance shall be three (3) times the nominal diameter, except where the edge is parallel to the direction of the applied force, the minimum edge distance of screw fasteners shall be 1.5 times the nominal diameter. Where the minimum center-to-center spacing is two (2) times the nominal diameter, screw fasteners shall be considered 80 percent effective.

#### D1.6 Gypsum Board

Gypsum board shall be attached to *cold-formed steel* framing in accordance with the *applicable building code* or an *approved* design standard. Screw fasteners for gypsum board to steel *connections* shall be in compliance with ASTM C954, ASTM C1002, or ASTM C1513, as applicable, with a bugle head style.

### D2 Welded Connections

Welded *connections* shall be in accordance with AISI S100 [CSA S136] and AWS D1.3. The design capacity of welds shall be in accordance with AISI S100 [CSA S136].

Welded areas shall be treated with an *approved* treatment to retain the corrosion resistance of the welded area.



### **D3 Other Connections**

#### **D3.1 Bolts**

Bolted *cold-formed steel* connections shall be designed and installed in accordance with AISI S100 [CSA S136].

#### **D3.2 Other Connectors**

Other types of *connections* (e.g. Pneumatically Driven Fasteners, Powder-Actuated Fasteners, Rivet Fasteners and Clinch Joining) shall be designed, fabricated and installed in accordance with the design requirements as set forth by an *approved* design or *approved* design standard, and the fastener manufacturer's requirements.

#### **D3.3 Connection to Other Materials**

Bolts, nails, anchor bolts or other fasteners used to connect *cold-formed steel* framing to wood, masonry, concrete or other steel components shall be designed and installed in accordance with the *applicable building code*, an *approved* design or *approved* design standard.

## **E. MISCELLANEOUS**

### **E1 Utilities**

#### **E1.1 Holes**

Holes shall comply with the requirements specified in Section B2.1. Penetrations of floor, wall and ceiling/roof assemblies which are required to have a fire resistance rating shall be protected in accordance with the *applicable building code* or in accordance with the requirements as stipulated by the authority having jurisdiction.

#### **E1.2 Plumbing**

All piping shall be provided with an isolative non-corrosive system to prevent galvanic action or abrasion between framing members and piping.

#### **E1.3 Electrical**

Wiring not enclosed in metal conduit shall be separated from the framing members by non-conductive non-corrosive grommets or by other *approved* means.

### **E2 Insulation**

#### **E2.1 Mineral Fiber Insulation**

Mineral fiber insulation (e.g. rock wool, glass fiber, etc.) for installation within cavities of framing members shall be full-width type insulation and shall be installed in accordance with the requirements as set forth by the *applicable building code* and insulation manufacturer. Compression of the insulation shall be permitted to occur at the open side of the *C-shaped* framing member.

#### **E2.2 Other Insulation**

Other types of insulation (e.g. foams, loose fill, etc.) for installation within cavities of framing members shall be installed in accordance with the *applicable building code* and insulation manufacturer's requirements. The width of insulation shall be dimensionally compatible with the *cold-formed steel* framing.



# **AISI** STANDARD

**Commentary on the  
North American Standard for  
Cold-Formed Steel Framing —  
General Provisions**

2012 Edition

## DISCLAIMER

The material contained herein has been developed by the American Iron and Steel Institute (AISI) Committee on Framing Standards. The Committee has made a diligent effort to present accurate, reliable, and useful information on cold-formed steel framing design and installation. The Committee acknowledges and is grateful for the contributions of the numerous researchers, engineers, and others who have contributed to the body of knowledge on the subject. Specific references are included in this *Commentary*.

With anticipated improvements in understanding of the behavior of cold-formed steel framing and the continuing development of new technology, this material will become dated. It is anticipated that AISI will publish updates of this material as new information becomes available, but this cannot be guaranteed.

The materials set forth herein are for general purposes only. They are not a substitute for competent professional advice. Application of this information to a specific project should be reviewed by a *design professional*. Indeed, in many jurisdictions, such review is required by law. Anyone making use of the information set forth herein does so at their own risk and assumes any and all liability arising therefrom.

1st Printing – April 2013

Copyright American Iron and Steel Institute 2012

## PREFACE

This *Commentary* is intended to facilitate the use and provide an understanding of the background of AISI S200, the *North American Standard for Cold-Formed Steel Framing – General Provisions*. The *Commentary* illustrates the substance and limitations of the various provisions of the standard.

In the *Commentary*, sections, equations, figures, and tables are identified by the same notation as used in the standard. Words that are italicized are defined in AISI S200. Terms included in square brackets are specific to Limit States Design terminology.

**This Page is Intentionally Left Blank.**

**TABLE OF CONTENTS**  
**COMMENTARY ON THE NORTH AMERICAN STANDARD FOR**  
**COLD-FORMED STEEL FRAMING –**  
**GENERAL PROVISIONS**

<b>DISCLAIMER .....</b>	<b>ii</b>
<b>PREFACE.....</b>	<b>iii</b>
<b>A. GENERAL .....</b>	<b>1</b>
A1 Scope.....	1
A2 Definitions .....	1
A3 Material .....	3
A4 Corrosion Protection .....	3
A5 Products .....	4
A5.2 Minimum Flange Width .....	5
<b>B. MEMBER DESIGN .....</b>	<b>6</b>
B1 Members .....	6
B2 Member Condition .....	6
B2.1 Web Holes .....	6
B2.2 Cutting, Patching, and Splicing.....	6
<b>C. INSTALLATION .....</b>	<b>7</b>
C1 In-Line Framing .....	7
C2 Installation Tolerances .....	7
C2.1 Foundations.....	7
C2.2 Ground Contact .....	7
C2.3 Floors.....	7
C2.4 Walls.....	8
C2.5 Roofs and Ceilings.....	9
<b>D. CONNECTIONS.....</b>	<b>10</b>
D1 Screw Connections .....	10
D1.1 Steel-to-Steel Screws .....	10
D1.4 Stripped Screws .....	12
D1.5 Spacing and Edge Distance.....	12
D1.6 Gypsum Board.....	12
D2 Welded Connections .....	12
D3 Other Connections.....	12
<b>E. MISCELLANEOUS .....</b>	<b>13</b>
E1 Utilities .....	13
E1.1 Holes .....	13
E1.2 Plumbing .....	13
E1.3 Electrical.....	13
E2 Insulation .....	13
<b>REFERENCES.....</b>	<b>15</b>

**This Page is Intentionally Left Blank.**



## COMMENTARY ON THE NORTH AMERICAN STANDARD FOR COLD-FORMED STEEL FRAMING – GENERAL PROVISIONS

### A. GENERAL

#### A1 Scope

AISI S200 (AISI, 2012b) applies to the design and installation of *structural members* utilized in *cold-formed steel* framing applications for load carrying purposes in buildings. Although the standard addresses the application of framing members having *base steel thickness* not greater than 118 *mils* (0.1180 inches) (2.997 mm), the standard does not preclude the use of other *cold-formed steel* members, assemblies, structures, or designs when they demonstrate equivalent performance for the intended use to those specified in the standard.

The standard is intended to serve as a supplement to AISI S100 [CSA S136], (AISI, 2012a; CSA, 2012).

In 2011, design provisions related to *nonstructural members* were moved to AISI S220, *North American Standard for Cold-Formed Steel Framing-Nonstructural Members* (AISI, 2011). However, use of the more stringent requirements for *structural members* that are in AISI S200 for *nonstructural members* should be permitted, since these should demonstrate equivalent performance for the intended use to those specified in AISI S220. Also in 2011, the lower limit on *base steel thickness* was deemed unnecessary and was eliminated.

#### A2 Definitions

Codes and standards by their nature are technical, and as such specific words and phrases can change the intent of the provisions if not properly defined. As a result, it is necessary to establish a common platform by clearly stating the meaning of specific terms for the purpose of this standard and other standards that reference this standard.

In the standard, *blocking* is defined to transfer shear force or to stabilize members. The following figures C-A2-1 and CA2-2 show examples of how *track* or *stud* members are used as *blocking* in various assemblies.

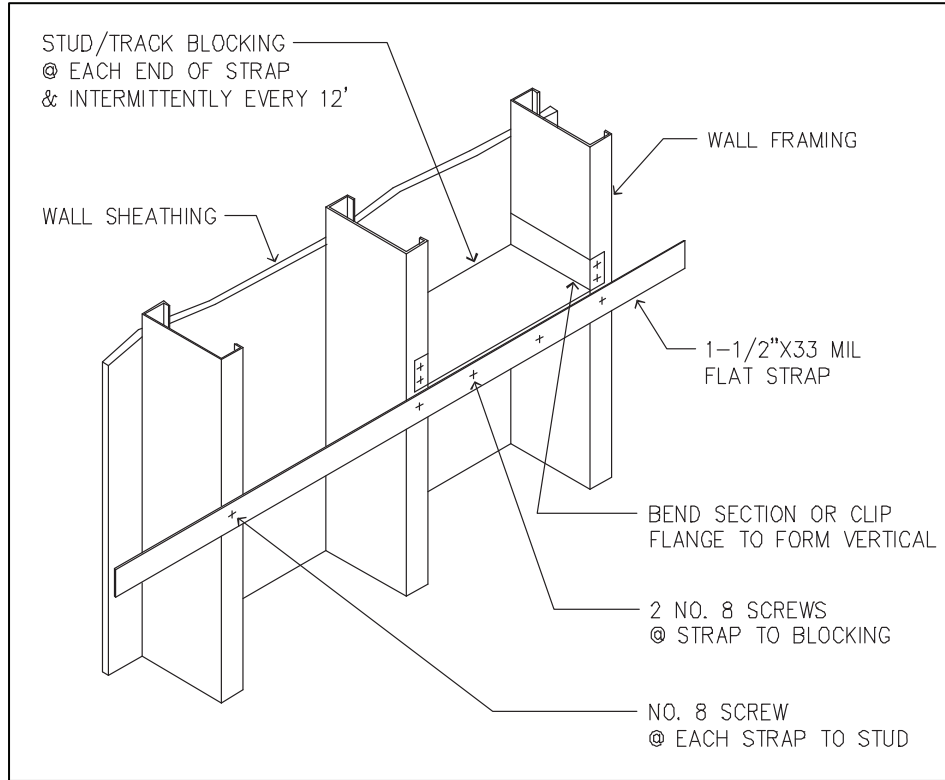

**Figure C-A2-1, Application of Stud Track Blocking**

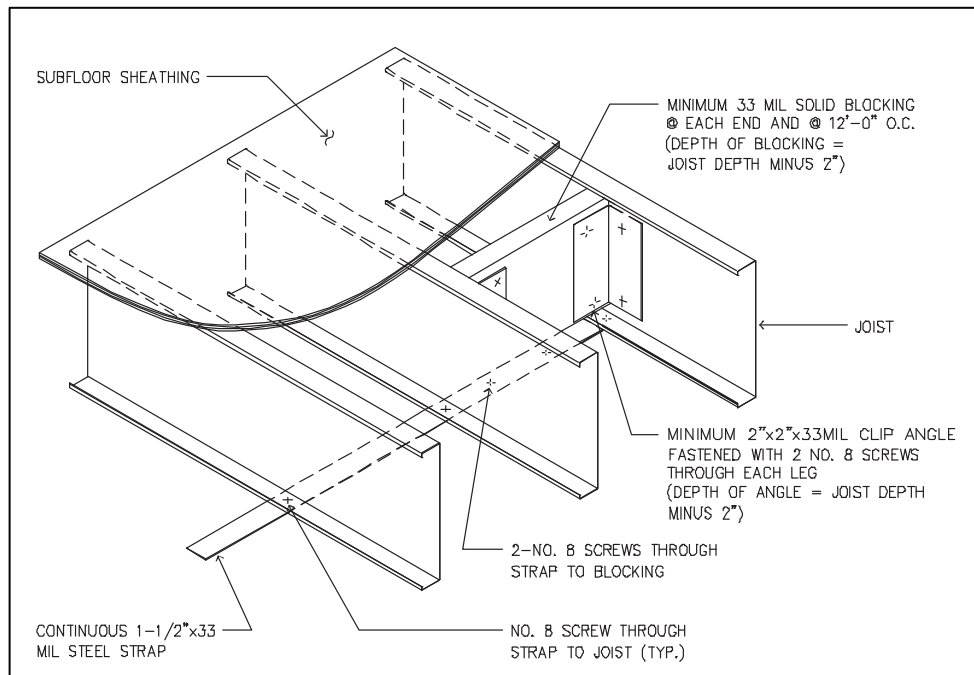

**Figure C-A2-2, Application of Joist Blocking**

### A3 Material

The sheet steel approved for use with this standard for *structural members* must comply with ASTM A1003/1003M (ASTM, 2011a). ASTM A1003/1003M covers the chemical, mechanical and coating requirements for steel sheet used in the manufacture of *cold-formed steel* framing members such as *studs, joists, and track*.

ASTM A1003/1003M is a standard that was developed in order to incorporate requirements for metallic-coated, painted metallic-coated, or painted nonmetallic-coated *steel sheet* used for *cold-formed steel* framing members into a single standard. Mechanical properties defined in ASTM A1003/A1003M are minimum requirements. For example, the minimum *yield strength* of Type H or L 33 [NS230] steel is 33 ksi [230 MPa]; material with higher *yield strength* is permitted, but 33 ksi [230 MPa] is the design *yield strength*. Additionally, according to the ASTM A1003/1003M Standard, Structural Grade Types H and L steel are intended for *structural members* and Non-Structural Grade Type NS steel is intended for *nonstructural members*. It is noted that additional country-specific limitations for *curtain wall studs* are provided in AISI S100 [CSA S136] (AISI, 2012a; CSA, 2012), A2.3.5, Appendix A or B.

Clarifications of the use of types H, L, and NS steels were provided in 2012 as part of an exercise to synchronize all codes and specifications. With the development of AISI S220 in 2011, Type NS of ASTM A1003/A1003M that is applicable for *nonstructural members* was removed from this standard.

### A4 Corrosion Protection

In 2012, as part of an exercise to synchronize all relevant codes and specifications, the provisions of Section A4.1 were consolidated from AISI S201 Section B3, ASTM C645 (ASTM, 2011b) and ASTM C955 (ASTM, 2011c).

The minimum coating designations listed in Table A4-1 of the standard assume normal exposure and construction practices. Other types of coatings that provide equal or better corrosion protection may also be acceptable. When more severe exposure conditions are probable, consideration should be given to specifying heavier coating weight [mass].

The minimum coating specified by this standard assumes normal exposure conditions that are best defined as having the framing members enclosed within a building envelope or wall assembly within a controlled environment. When more severe exposure conditions are probable, such as industrial atmospheres and marine atmospheres, consideration should be given to specifying a heavier coating. Coating is specified by weight or mass.

This standard does not require the edges of metallic-coated *cold-formed steel* framing members, shop or field cut in accordance with Section B2.2.1, punched or drilled, to be touched up with zinc-rich paint, which is able to galvanically protect steel. When base steel is exposed, such as at a cut or scratch, the steel is cathodically protected by the sacrificial corrosion of the zinc coating, because zinc is more electronegative (more reactive) than steel in the galvanic series. A zinc coating will not be undercut because the steel cannot corrode adjacent to the zinc coating. Therefore, any exposure of the underlying steel at an edge or scratch will not result in corrosion of the steel away from the edge or scratch and thus will not affect the performance of the coating or the steel structure (CFSEI, 2007a).

It is noted that ASTM A1004/A1004M (ASTM, 2009) covers procedures for establishing the acceptability of *steel sheet* for use as *cold-formed steel* framing members. This practice is to be used to assess the corrosion-resistance of different coatings on *steel sheet* in a laboratory test. It is not intended to be used as an application performance standard for the *cold-formed steel* framing, but

is to be used to evaluate coatings under consideration for addition to ASTM A1003/A1003M (ASTM, 2011a).

Direct contact with dissimilar metals (e.g. copper, brass, etc.) should be avoided in order to prevent unwanted galvanic action from occurring. Methods for preventing the contact from occurring may be through the use of non-conductive non-corrosive grommets at *web* penetrations or through the use of non-metallic brackets (a.k.a. isolators) fastened to hold the dissimilar metal building products (e.g. piping) away from the *cold-formed steel* framing. In 2006, a change was made to this standard allowing the use of dissimilar metals in contact with *cold-formed steel* framing provided the specific application is approved. It was recognized that dissimilar metals in contact might not always be a problem. For example, there are no galvanic concerns where there is no moisture. A special case of dissimilar metals occurs in Canada where, for certain climatic conditions and building heights, the use of stainless steel brick ties is required. When these ties are connected to steel *stud* backup, contact between dissimilar metals can occur. For guidance on this dissimilar metals issue, refer to the Canadian Standard, CAN/CSA-A370-04, *Connectors for Masonry* (CSA, 2009).

When there is direct contact of *cold-formed steel* framing with pressure-treated wood, the treated wood, *cold-formed steel* framing, connector and/or fastener manufacturers should be contacted for recommendations. Methods that should be considered may include specifying a less corrosive pressure treatment (sodium borate, organic preservative systems, etc.), isolating the *cold-formed steel* and wood components, or changing details to avoid use of pressure-treated wood altogether.

*Design professionals* should take into account both the initial contact with wet or damp building materials, as well as the potential for those materials to absorb water during the building's life, as both circumstances may accelerate corrosion.

In 2007, the Cold-Formed Steel Engineers Institute updated the 2004 AISI document "Durability of Cold-Formed Steel Framing Members" (CFSEI, 2007a) to give engineers, architects, builders and homeowners a better understanding of how galvanizing (zinc and zinc-alloy coatings) provides long-term corrosion protection to *cold-formed steel* framing members. Additional information can be obtained from the American Galvanizers Association publication "Hot Dip Galvanizing For Corrosion Protection - A Specifier's Guide" (AGA, 2006) and the Cold-Formed Steel Engineers Institute's publication "Corrosion Protection for Cold-Formed Steel Framing in Coastal Areas" (CFSEI, 2007b).

In 2011, corrosion protection requirements for *nonstructural members* were moved to AISI S220 (AISI, 2011).

## **A5 Products**

AISI S100 [CSA S136], (AISI, 2012a; CSA, 2012) permits the minimum delivered *base steel thickness* (exclusive of any coatings) of a *cold-formed steel* member to be 95% of the *design thickness*. This standard therefore specifies the minimum *base steel thickness* that complies with AISI S100 [CSA S136]. The thickness designations are consistent with standard industry practice, as published in AISI S201 (AISI, 2012c). It is recommended that thickness measurements be taken in the middle of the flat of the *flange* or *web* of the cross-section.

AISI S201 has adopted a standard designator system for identifying *cold-formed steel* framing members. The intent for using a standard designator system is to overcome the varied designators that are produced by each individual manufacturer. In addition, the designator is used to identify not only a specific *cold-formed steel* framing member, but also the section properties of that same member through the use of the manufacturer's product technical

information documents.

The following presents an example of the standard designator for a *cold-formed steel stud*:

350S162-33 represents a member with the following:

**350S162-33**

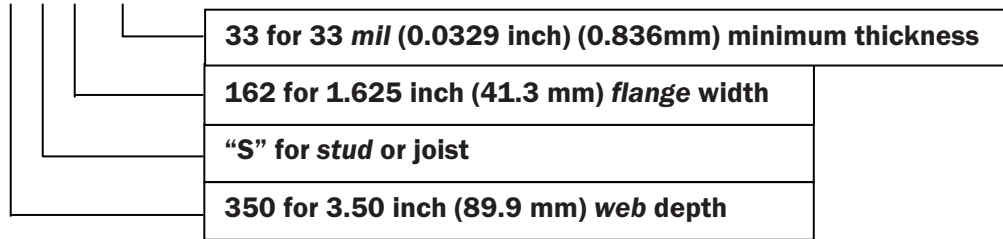

In 2012, as part of an exercise to synchronize all relevant codes and specifications, the minimum tolerances for the manufacture of *structural members* utilized in *cold-formed steel* framing were moved from the Commentary to the Standard Section A5. In 2011, the minimum tolerances for the manufacture of *nonstructural members* were moved to AISI S220 (AISI, 2011). The manufacturing tolerances for length, *web* width, camber, bow, twist, etc. of framing members were consistent with ASTM C955 (ASTM 2011c) and ASTM C645 (ASTM, 2011b).

To aid in shop and field verification, all framing members need to carry a product identification to indicate conformance with the minimum *base steel thickness*, coating designation, minimum *yield strength*, and manufacturer’s name. In 2012, as part of an exercise to synchronize all relevant codes and specifications, the provisions of Section A5.4 of the standard were consolidated from AISI S201 Section C6, ASTM C645 and ASTM C955.

In 2012, color coding of individual framing members or groups of like members were removed with consideration that the color coding approach may cause confusion in differentiating between *structural* and *nonstructural members* of the same thickness. Further, color coding is optional and the criterion, if needed, exists in a non-mandatory Appendix of ASTM C645.

**A5.2 Minimum Flange Width**

In 2012, as part of an exercise to synchronize all relevant codes and specifications, the provisions of Section A5.2 were consolidated from ASTM C645 and ASTM C955. The minimum *flange* width for *C-shape* members was included in the standard to accommodate a butt joint of sheathing. The minimum *flange* width for *track* members was included in the standard to accommodate an edge joint of sheathing.

## B. MEMBER DESIGN

### B1 Members

The strength determinations required by this standard are to be in accordance with AISI S100 [CSA S136] (AISI, 2012a; CSA, 2012). For design guidance on the application of AISI S100 [CSA S136] to typical *cold-formed steel* construction refer to *Design Guide for Cold-Formed Steel Framing* (AISI, 2007) and *Cold-Formed Steel Design* (Yu, 2010).

### B2 Member Condition

To ensure that structural performance is in compliance with the engineered design, framing members must not be damaged. Damage assessment is not within the purview of this standard. The *design professional* should be consulted when damage alters the cross-section geometry of a framing member beyond the specified tolerances.

#### B2.1 Web Holes

AISI S100 [CSA S136] stipulates design requirements for members with standard *web* holes. In the field, these “*web* holes” may also be referred to as “*punchouts*”, “*utility holes*”, “*perforations*” and “*web penetrations*”. In *structural members*, *web* holes are typically 1.5 in. (38 mm) wide x 4 in. (102 mm) long and are located on the centerline of the *web* depth. The *web* holes are generally spaced 24 in. (610 mm) on-center.

#### B2.2 Cutting, Patching, and Splicing

This standard places restrictions on acceptable methods for cutting of framing members so that cut edges are not excessively rough or uneven and protective metallic coatings are not damaged in areas away from cut edges. Shearing *cold-formed steel* framings during manufacturing, fabrication and installation may be performed in a variety of ways. Shearing methods include but are not limited to the following:

- Hydraulic shears,
- Hydraulic hole punches,
- Portable hydraulic shears,
- Hand-held electric shears,
- Aviation snips, and
- Portable hole punches.

Coping, cutting or notching of *flanges* and *edge stiffeners* is not permitted for *structural members* without an *approved* design. For guidance on design for coped members in *trusses*, refer to AISI S214 (AISI, 2012d).

*Structural members* may be spliced; however, splicing of *studs* and *joists* is not a common practice and is not recommended. If a *structural member* requires splicing, the splice *connection* must be installed in accordance with an *approved* design.

## C. INSTALLATION

### C1 In-Line Framing

In-line framing is the preferred and most commonly used framing method. The advantage of in-line framing is that it provides a direct *load* path for transfer of forces from *joists* to *studs*. The standard stipulates maximum framing alignment to minimize secondary moments on the framing members. The weak axis bending strength of *track* is minimal and therefore the *track* cannot function as a *load* transfer member. In the absence of in-line framing, a *load* distribution member, such as a structural *track*, may be required for this force transfer.

For a *cold-formed steel joist* floor system, the capacity of the inter-story *load* path is defined by Section C3.4 of AISI S100 [CSA 136] (AISI, 2012a; CSA, 2012) based on web crippling of the *joist* alone or Section C3.7 of AISI S100 [CSA 136] when a *bearing stiffener* is employed. Industry practice has accepted in-line framing to mean that the *joist*, *rafter*, *truss* and structural wall *stud* framing would be aligned so that the centerline (mid-width) is within  $\frac{3}{4}$  inch (19 mm) of the centerline (mid-width) of the *load* bearing members beneath. However, the  $\frac{3}{4}$ -inch (19-mm) allowable offset creates the possibility for a misalignment in the *load* path from an upper story *load* bearing *stud* wall, through a *joist* with a *bearing stiffener* and onto a *load* bearing *stud* or foundation wall below. In 2003, a total of 110 end- and interior-two-flange loading tests of various floor *joist* assemblies were carried out at the University of Waterloo (Fox, 2003) to determine the effect that an offset loading has on the strength of typical floors. It was concluded that an additional limit should be placed on the *bearing stiffener* offset to the *load* bearing members above or beneath for cases where the *bearing stiffener* is attached to the back of the *joist* as depicted in Figure C1-1 in the standard.

As an alternative to in-line framing, the standard permits the use of a structural *load* distribution member that is specified in accordance with an *approved* design or *approved* design standard. As an aid to designers, strength and stiffness have been determined experimentally for various *load* bearing top track assemblies (NAHB-RC, 2003; Dawe, 2005), including standard steel *track*, deep-leg steel *track*, and steel *track* with a 2x wood top plate. Design guidance for some of the typical top track *load* distribution members is available from the Cold-Formed Steel Engineers Institute (CFSEI, 2010a).

### C2 Installation Tolerances

#### C2.1 Foundations

An uneven foundation may cause problems. The specified  $\frac{1}{4}$ -in. (6.4-mm) gap has been deemed acceptable industry practice.

#### C2.2 Ground Contact

To minimize the potential for corrosion, care must be taken to avoid direct contact between the *cold-formed steel* framing and the ground. In addition to direct contact, it is important to minimize the potential for corrosion resulting from ambient moisture. The *applicable building code* is cited as the authoritative document that will provide guidance concerning minimum separation distances from the ground to the framing member, installation requirements for moisture barriers, and the necessary ventilation of the space.

#### C2.3 Floors

To avoid premature failure at a support and to achieve in-line framing, full bearing of the

*joist* on its supporting wall is necessary. The intent of specifying that the *track* and *joist webs* are not to be in direct contact with each other is to prevent floors from creating an unwanted noise (e.g. squeaks).

## **C2.4 Walls**

### **C2.4.1 Straightness, Plumbness and Levelness**

Wall *studs* must be installed plumb to avoid the potential for secondary bending moments in the member.

### **C2.4.4 End Bearing**

The *stud* must be nested and properly seated into the top and bottom *track* to provide for adequate transfer of forces and minimize axial deflections. Each *flange* of the *stud* should also be attached to the *tracks* to brace the top and bottom of the *stud* against weak axis and torsional displacements.

The maximum end gap tolerance specified by this standard is based on traditional industry practice. The tolerances specified in standard section C2.4.4 are only for axial load bearing walls, which is defined in Section 202 of the IBC (ICC, 2012) as any metal or wood stud wall that supports more than 100 pounds per linear foot (1459 N/m) of vertical *load* in addition to its own weight.

Axial *loads* in a wall *stud* in excess of the capacity of the screw *connection* between the *stud* and its seating *tracks* will be transferred between the *stud* and *track* in bearing. In this situation, if a *stud* is not properly seated, relative movement between the *stud* and the *track* may occur, which reduces or closes any gap between the end of the *stud* and the *track*.

To determine the influence of this relative movement between the *stud* and the *track* on the serviceability of sheathed wall assemblies, a testing program was conducted at the University of Missouri-Rolla (Findlay, 2005). The UMR test program only considered the *stud* and the *track* having the same thickness. For thinner *stud* and *track* materials (0.054 inches (1.37 mm) or less), testing showed that relative movement between the *stud* and the *track* was accommodated through a combination of *track* deformation and screw tilting. In these cases, the *connection* remained intact and was capable of resisting uplift forces and preventing *stud* weak axis and torsional displacement. For thicker materials (greater than 0.054 inches), testing showed that the relative movement between the *stud* and the *track* could result in shear failure of the screws. In these cases, testing indicated a smaller end gap tolerance (e.g., 1/16 inch (1.59 mm)) would be desirable to limit relative movement and potential screw failure.

In addition to a smaller end gap tolerance to avoid potential screw failure in *track* thicker than 0.054 inches (1.37 mm), a smaller gap tolerance may also be desirable for multi-story structures where the accumulation of gap closures may become significant. Special considerations may also be desirable for heavily loaded cold-formed steel structures and conditions susceptible to deflections.

One method to help achieve adequate end bearing and minimize undesirable relative movement between the *stud* and the *track* is to specify a smaller 1/16-in. (1.59-mm) maximum gap. This is a relatively simple criterion to verify. However, the 1/16-in. (1.59-mm) maximum gap is on occasion difficult to achieve, particularly with 0.097 in. (2.46 mm) or thicker *track*.

Another method to achieve adequate end bearing is to pre-compress the *stud* inside the



*track*. This is often accomplished when panelizing the *stud* walls and pre-compressing the wall panel before connecting the *track* to the *studs*. Wall panelization and pre-compression, particularly for multi-story *cold-formed steel* construction, have become common practice in several regions of North America. With pre-compression, it can be relatively ensured that the *stud* will be seated in the *track*, regardless of the gap after pre-compression. At present, there are no specific guidelines for the amount of pre-compressive force required to ensure proper seating. Industry practice has been to compress the wall panel until the *studs* visually seat inside the radius of the *track* and before the *studs* begin to buckle. Jacking force will vary depending upon the *stud* size and wall panel height, but is typically several hundred pounds minimum per *stud*. Guidelines for verification of proper pre-compression are nonexistent, but typically pre-compression will result in gaps of 1/16 in. (1.59 mm) or less for the majority of *stud-to-track* connections, with no gap exceeding 1/8 inch (3.18 mm).

A third method to help ensure adequate end bearing is to oversize the *web* depth of the *track* to minimize any gap. *Track* oversized 1/16 to 1/8 in. (1.59 mm to 3.18 mm) will usually have a flat web between the *track* radii that is greater than the depth of the *stud*, enabling the *stud* to bear directly on the web instead of the *track* radii. This method will often be desirable when bearing walls are stick-framed instead of panelized and pre-compressed. One disadvantage is that the oversized *track* may make a flat wall finish more difficult.

For all thickness of materials, testing has shown that the gap between the sheathing and the floor should be equal to or greater than the gap between the *stud* and the *track*.

## **C2.5 Roofs and Ceilings**

Proper installation and alignment of roof *joists* and ceiling *joists* is necessary to ensure the proper *load* transfer from the *rafter/ceiling joist connection* to the wall framing. To avoid premature failure at a support and to achieve in-line framing, full bearing of the *joist* on its supporting wall framing member or a minimum 1-1/2 inch (38 mm) end bearing is necessary.

## D. CONNECTIONS

### D1 Screw Connections

#### D1.1 Steel-to-Steel Screws

Screws are the primary fastener type used in *cold-formed steel* framed construction, although the standard does not preclude the use of other fastener types. In 2001, ASTM C1513 (ASTM, 2010b) was first published, covering screws for the *connection* of *cold-formed steel* members manufactured in accordance with ASTM Specifications C645 and C955. This specification also covers test methods for determining performance requirements and physical properties. However, the tensile or shear strength must be determined by test in accordance with AISI S904-08 (AISI, 2008). General guidance on the selection of screws is given by the Cold-Formed Steel Engineers Institute document “Screw Fastener Selection for Cold-Formed Steel Frame Construction” (CFSEI, 2011).

Proper selection and installation of screws are necessary to ensure the design performance. Screws are specified using a nominal size designator, not by diameter. Table D1-1 defines suggested nominal screw diameters. The installation requirements stated in AISI S200 are based on industry practice. Selection of a minimum screw size is based on the total sheet thickness of the *connection*. Where recommendations are not available, Table D1-2 provides suggested screw size for steel-to-steel *connections* as a function of point style, per ASTM C1513, and total combined thickness of all connected steel members.

**Table D1-1**  
**Suggested Screw Body Diameter**

Screw Nominal Size	Nominal Screw Diameter, $d$	
	(inches)	(mm)
No. 6	0.138	3.51
No. 8	0.164	4.17
No. 10	0.190	4.83
No. 12	0.216	5.49
1/4"	0.250	6.35



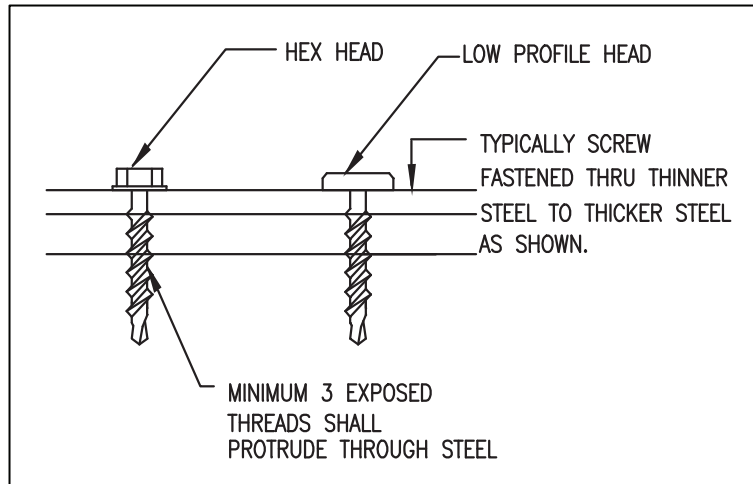

**Figure D1-1 - Screw Grip Range**

**Table D1-2  
Suggested Screw Sizes For Steel-to-Steel Connections**

Screw Size	Point Style	Total Thickness of Steel <sup>1</sup>	
		(inches)	(mm)
¼	1	0.024 - 0.095	0.61 - 2.41
6	2	0.036 - 0.100	0.91 - 2.54
8	2	0.036 - 0.100	0.91 - 2.54
10	2	0.036 - 0.110	0.91 - 2.79
12	2	0.050 - 0.140	1.27 - 3.56
14	2	0.060 - 0.120	1.52 - 3.05
18	2	0.060 - 0.120	1.52 - 3.05
8	3	0.100 - 0.140	2.54 - 3.56
10	3	0.110 - 0.175	2.79 - 4.45
12	3	0.090 - 0.210	2.29 - 5.33
14	3	0.110 - 0.250	2.79 - 6.35
12	4	0.175 - 0.250	4.45 - 6.35
¼	4	0.175 - 0.250	4.45 - 6.35
12	4.5	0.145 - 0.312	3.68 - 7.92
12	5	0.250 - 0.500	6.35 - 12.7
¼	5	0.250 - 0.500	6.35 - 12.7

<sup>1</sup> Combined thickness of all connected steel members

#### **D1.4 Stripped Screws**

It is unreasonable to expect that there will be no stripped screws in a *connection*. Research at the University of Missouri-Rolla, (Sokol et al., 1999) has shown that the structural performance of a single-shear screw *connection* is not compromised if screws in the *connection* have been inadvertently stripped during installation. This research serves as the basis for the requirements of the standard.

#### **D1.5 Spacing and Edge Distance**

AISI S100 [CSA S136], (AISI, 2012a; CSA, 2012) stipulates that the center-to-center spacing of screws be at least three (3) times the screw diameter. During installation, if this spacing is only two (2) times the diameter, research at the University of Missouri-Rolla (Sokol et al., 1999) has shown that the structural performance of the *connection* is reduced. Guidelines for center-to-center spacing of less two (2) times the diameter are not stipulated because the screw head diameter precludes a smaller spacing. The University of Missouri-Rolla research serves as the basis for the requirements in the standard.

#### **D1.6 Gypsum Board**

The standard employs the use of the *applicable building code* as the guide for provisions that cover the installation and attachment of gypsum panels to *cold-formed steel* framing. The model building codes in the United States reference ASTM C1007 (ASTM, 2011d) as the appropriate standard for the gypsum board attachment to *cold-formed steel structural members*.

The standard requires that screw fasteners for gypsum board to steel *connections* be in compliance with ASTM C954 (ASTM, 2010a), ASTM C1002 (ASTM, 2007) or ASTM C1513 (ASTM, 2010b), as applicable, with a bugle head style. ASTM C954 is for fastening to steel having a thickness from 0.033 inches (0.838 mm) to 0.112 inches (2.84 mm). ASTM C1002 is for fastening to steel with a thickness less than 0.033 inches (0.838 mm). ASTM C1513 is for fastening to steel with a thickness not greater than 0.118 inches (2.997 mm).

### **D2 Welded Connections**

To maintain acceptable durability of a welded *connection*, the weld area must be treated with a corrosion-resistant coating, such as a zinc-rich paint. Additional guidance on welding of *cold-formed steel* members is provided in the Cold-Formed Steel Engineers Institute document "Welding Cold-Formed Steel" (CFSEI, 2010b).

### **D3 Other Connections**

The standard permits the use of bolts and proprietary fasteners, such as pneumatically driven pins, powder-actuated fasteners, rivets, adhesives, and clinches. Bolts can be designed by AISI S100 [CSA S136] equations. However, proprietary fasteners must be designed and installed in accordance with the manufacturer's requirements. The *safety factor* to be used in design is to be determined by Chapter F of AISI S100 [CSA S136]. The Cold-Formed Steel Engineers Institute publishes technical notes pertaining to powder-actuated fasteners and pneumatically driven pins (CFSEI, 2012; CFSEI, 2009).

## E. MISCELLANEOUS

### E1 Utilities

#### E1.1 Holes

The design should include references to pre-punch hole sizes or limitations to accommodate electrical, telecommunication, plumbing and mechanical systems. Field-cut holes are generally discouraged, but are not uncommon. Field-cut holes, if necessary, are required to comply with Section B2.1 of the standard. There are several methods whereby holes can be cut in the field, such as a hole-punch, hole saws, and plasma cutters.

Holes that penetrate an assembly containing steel framing that has a fire resistance rating will need to be designed with through-penetration firestop systems. The acceptance of this fire resistance design is based on the *applicable building code*.

#### E1.2 Plumbing

Direct contact with copper piping should be avoided in order to prevent galvanic action from occurring. Methods for preventing the contact from occurring may be through the use of non-conductive non-corrosive grommets at *web* penetrations or through the use of non-metallic brackets (a.k.a. isolators) fastened to hold the dissimilar metal building products (e.g. piping) away from the steel framing. Plastic pipe does not require protection if it is in contact with the *cold-formed steel* framing member, but consideration should be given to the installation of non-metallic brackets to hold the pipe away from the hole in the steel in order to prevent noise and prevent the steel from cutting into the pipe.

#### E1.3 Electrical

Non-metallic sheathed wiring must be separated from the *cold-formed steel* framing member in order to comply with the *National Electrical Code* (NFPA, 2011). Contained within the *National Electrical Code* is a provision that requires non-metallic sheathed cable to “be protected by bushings or grommets securely fastened in the opening prior to the installation of the cable.” Cable following the length of a framing member will need to be secured (e.g. supported) at set lengths. For this purpose, small holes in the *web* may be beneficial for the attachment of tie-downs (e.g. nylon cable ties, nylon zipper ties, etc). When installing wiring or cables within a framing member (e.g. through or parallel to the member), the intent of the *National Electrical Code* further requires that the wiring or cables be located 1-1/4 inches (32 mm) from the edge of the framing member. When 2-1/2 inch (64 mm)-wide wall *studs* are used, the restrictions concerning edge clearance apply.

### E2 Insulation

The cavity insulation must be installed such that the width of the insulation extends from the face of the *web* of one framing member to the face of the *web* of the next framing member. In the case of *cold-formed steel* framing, designs should specify “full width” insulation in order to differentiate the insulation that is normally supplied (e.g. nominal width).

To enhance the thermal performance of *cold-formed steel* framed construction, board insulation (e.g. continuous insulation or insulating sheathing) may be used in conjunction with cavity insulation. Guidance on the use of board and batt insulation is given in “Thermal Design and Code Compliance for Cold-Formed Steel Walls” (SFA, 2008). Designs should also take into

consideration the effects of moisture when assessing the application of both cavity and continuous insulation, in this case dew point. The ASHRAE *Handbook of Fundamentals* contains information useful for determining the value of dew point (ASHRAE, 2009).

## REFERENCES

- (AGA, 2006), *Hot Dip Galvanizing For Corrosion Protection - A Specifier's Guide*, American Galvanizers Association, Aurora, CO, 2006.
- (AISI, 2012a), *North American Specification for the Design of Cold-Formed Steel Structural Members*, AISI S100-12, American Iron and Steel Institute, Washington, DC, 2012.
- (AISI, 2012b), *North American Standard for Cold-Formed Steel Framing – General Provisions*, AISI S200-12, American Iron and Steel Institute, Washington, DC, 2012.
- (AISI, 2012c), *North American Standard for Cold-Formed Steel Framing – Product Data*, AISI S201-12, American Iron and Steel Institute, Washington, DC, 2012.
- (AISI, 2012d), *North American Standard for Cold-Formed Steel Framing – Truss Design*, AISI S214-12, American Iron and Steel Institute, Washington, DC, 2012.
- (AISI, 2011), *North American Standard for Cold-Formed Steel Framing – Nonstructural Members*, AISI S220-11, American Iron and Steel Institute, Washington, DC, 2011.
- (AISI, 2008), *Standard Test Methods for Determining the Tensile and Shear Strength of Screws*, AISI S904-08, American Iron and Steel Institute, Washington, DC, 2008.
- (AISI, 2007), *Design Guide for Cold-Formed Steel Framing*, D110-07, American Iron and Steel Institute, Washington, DC, 2007.
- (ASHRAE, 2009), *ASHRAE Handbook Fundamentals*, American Society of Heating Refrigerating and Air-conditioning Engineers, Atlanta, GA, 2009.
- (ASTM, 2011a), *Standard Specification for Steel Sheet, Carbon, Metallic- and Nonmetallic-Coated for Cold-Formed Framing Members*, ASTM A1003/1003M-11, ASTM International, West Conshohocken, PA, 2011.
- (ASTM, 2011b), *Standard Specification for Nonstructural Steel Framing Members*, ASTM C645-11, ASTM International, West Conshohocken, PA, 2011.
- (ASTM, 2011c), *Standard Specification for Load-Bearing (Transverse and Axial) Steel Studs, Runners (Tracks), and Bracing or Bridging for Screw Application of Gypsum Board and Metal Plaster Bases*, ASTM C955-11, ASTM International, West Conshohocken, PA, 2011.
- (ASTM, 2011d), *Standard Specification for Installation of Load Bearing (Transverse and Axial) Steel Studs and Related Accessories*, ASTM C1007-11, ASTM International, West Conshohocken, PA, 2011.
- (ASTM, 2010a), *Standard Specification for Steel Drill Screws for the Application of Gypsum Panel Products or Metal Plaster Bases to Steel Studs From 0.033 in. (0.84 mm) to 0.112 in. (2.84 mm) in Thickness*, ASTM C954-10, ASTM International, West Conshohocken, PA, 2010.
- (ASTM, 2010b), *Standard Specification for Steel Tapping Screws for Cold-Formed Steel Framing Connections*, ASTM C1513-10, ASTM International, West Conshohocken, PA, 2010.
- (ASTM, 2009), *Standard Practice for Establishing Conformance to the Minimum Expected Corrosion Characteristics of Metallic, Painted-Metallic, and Nonmetallic-Coated Steel Sheet Intended for Use as Cold-Formed Framing Members*, ASTM A1004/A1004M-99 (2009), ASTM International, West Conshohocken, PA, 2009.
- (ASTM, 2007), *Standard Specification for Steel Self-Piercing Tapping Screws for the Application of Gypsum Panel Products or Metal Plaster Bases to Wood Studs or Steel Studs*, ASTM C1002-07, ASTM International, West Conshohocken, PA, 2007.
- (CFSEI, 2012), *Powder Actuated Fasteners in Cold-Formed Steel Construction*, Tech Note F301-12, Cold-Formed Steel Engineers Institute, Washington, DC, 2012.

- (CFSEI, 2011), *Screw Fastener Selection for Cold-Formed Steel Frame Construction*, Tech Note F102-11, Cold-Formed Steel Engineers Institute, Washington, DC, 2011.
- (CFSEI, 2010a), *Top Track Load Distribution Members*, Tech Note W104-10, Cold-Formed Steel Engineers Institute, Washington, DC, 2010.
- (CFSEI, 2010b), *Welding Cold-Formed Steel*, Tech Note 560-b1, Cold-Formed Steel Engineers Institute, Washington, DC, 2010.
- (CFSEI, 2009), *Pneumatically Driven Pins For Wood Based Panel Attachment*, Tech Note F300-09, Cold-Formed Steel Engineers Institute, Washington, DC, 2009.
- (CFSEI, 2007a), *Durability of Cold-Formed Steel Framing Members*, Tech Note D001-07, Cold-Formed Steel Engineers Institute, Washington, DC, 2007.
- (CFSEI, 2007b), *Corrosion Protection for Cold-Formed Steel Framing in Coastal Areas*, Tech Note D200-07, Cold-Formed Steel Engineers Institute, Washington, DC, 2007.
- (CSA, 2012), *North American Specification for the Design of Cold-Formed Steel Structural Members*, CAN/CSA S136-12, Canadian Standards Association, Mississauga, Ontario, Canada, 2012.
- (CSA, 2009), *Connectors for Masonry*, CAN/CSA-A370-04(R2009), Canadian Standards Association, Mississauga, Ontario, Canada, 2009.
- Dawe, J.L. (2005), "Experimental Evaluation of the Strength and Behaviour of 16- and 18-gauge Cold Formed Steel Top Track Systems - 92 mm and 152 mm, 16" and 24" Spans (W & W/O 2X4 and 2X6 Wood Top Plates)," University of New Brunswick Structural Engineering Laboratory, Saint John, New Brunswick, Canada, 2005.
- Findlay, P.F. (2005), "Serviceability Issues Pertaining to Load Bearing and Non-Load Bearing Steel Framed Walls," Thesis presented to the faculty of the University of Missouri-Rolla in partial fulfillment of the degree, Master of Science, Rolla, MO, 2005.
- Fox, S.R. (2003), "The Strength of Stiffened CFS Floor Joist Assemblies With Offset Loading," American Iron and Steel Institute, Washington, DC.
- (ICC, 2012), *International Building Code*, International Code Council, Washington, DC, 2012.
- (NAHB-RC, 2003), *Cold-Formed Steel Top Load Bearing Tracks*, NAHB Research Center, Upper Marlboro, MD, 2003.
- (NFPA, 2011), *National Electrical Code (NFPA 70)*, National Fire Protection Association, Quincy, MA, 2011.
- Sokol, M.A., LaBoube, R.A., and Yu, W.W. (1999), "Determination of the Tensile and Shear Strengths of Screws and the Effect of Screw Patterns on Cold-Formed Steel Connections," Civil Engineering Study 98-3, Cold-Formed Steel Series, Center for Cold-Formed Steel Structures, University of Missouri-Rolla, Rolla, MO, 1999.
- (SFA, 2008), *Thermal Design and Code Compliance for Cold-Formed Steel Walls*, Steel Framing Alliance, Washington, DC, 2008.
- Yu, W.W. and LaBoube, R.A. (2010), *Cold-Formed Steel Design*, 4<sup>th</sup> Edition, John Wiley & Sons, New York, NY, 2010.





**American  
Iron and Steel  
Institute**

25 Massachusetts Avenue, NW  
Suite 800  
Washington, DC 20001  
[www.steel.org](http://www.steel.org)

